

## INTRODUCTION

The K-Dyne, Inc. electric version of the Model L80 is a 2" NPT mounted liquid level switch. It is typically mounted in a K-Dyne Model C80 cage shown in the figure 1 for external bridle mounting or may be internally mounted in a 2" NPT (F) connection. Both mounting configurations are shown in figure 2.

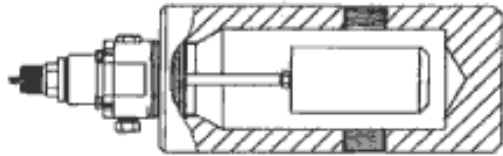

FIGURE 1  
MODEL L80 SHOWN IN MODEL C80 FLANGE

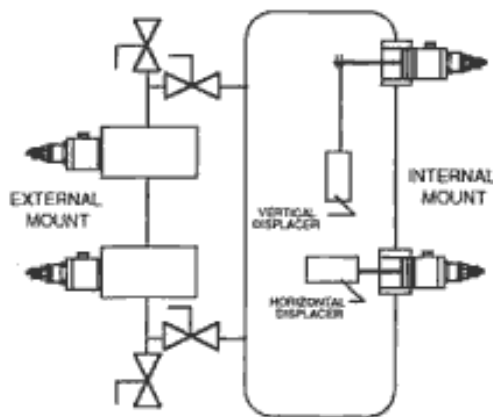

FIGURE 2  
TYPICAL MOUNTING OF MODEL L80  
LEVEL SWITCHES

These sensors send or remove a pneumatic signal when a liquid in a tank or a pressurized vessel reaches a predetermined level. The L80 operation mode as either a low (direct) or high (reverse) acting level switch is selected by rotating the pivot body 180°. Selection of N.O. or N.C. switching depends upon the wiring configuration utilized. Both SPDT or DPDT snap acting dry contacts offered with the switch are U.L.T rated for hazardous locations.

## 2.0 PRINCIPLE OF OPERATION (Refer to Figure 3)

The electric version of the K-Dyne, Inc. Model L80 2" NPT mounted liquid level switch is a multi-functional pneumatic liquid level sensor. Depending on the mode of operation, it functions as a three way, normal closed (N.C.) or normally open (N.O.) electric switch that will operate when the liquid level rises or falls below a fixed point in a tank or pressurize vessel. Type of voltage may be A.C. or D. C. and the maximum amperage depends on the

amount of voltage used. Consult the data sheet of the specific switch being used for the switch rating.

The switch senses a change in the buoyancy of a displacer assembly (9) inside either a pressurized or an unpressurized vessel. A pivoting action is used to transmit the buoyancy change of the displacer assembly. The bore of the cone (14) contacts a pivot (13) on the pivot body (3). The o-ring (8) provides a pressure tight seal between the body (7) and the shaft of the cone protruding through the o-ring.

Pressure in the vessel acting on the shaft of the cone forces the cone against the pivot. The position of the pivot point, at the center of the o-ring, allows the displacer assembly to move vertically with the liquid level. This motion is guided to act along the axis of the transverse rod (16) by two vertical tabs on the pivot body that mate with notches in the cone. Any vertical motion of the displacer is transmitted by the cone to the ends of the transverse rod. A ramp on the outside diameter of the transverse rod contacts the tip of the push rod (17) to operate the lever on the switch assembly (2).

## 2.1 LOW OPERATION

For use as a low-level sensor (output on rising level), the pivot body (13) is positioned with the enlarged end of the transverse rod (16) up towards the spring cap (4). The displacer assembly weight exerts a clockwise rotational force on the cone through the pivot. The spring (5), acting through the spring guide (6) exerts a counterclockwise rotational force on the cone. When the liquid level is below the displacer assembly, the clockwise force is greater. This force causes the cone to push upward against the transverse rod allowing the tip of the push rod to be positioned away from the switch assembly lever. In this position N.O. or N.C. contacts are in the normal position (i.e. N.O. contacts are open and N.C. contacts are closed).

As the liquid level rises and begins to cover the displacer assembly, its buoyancy, in the liquid, reduces the clockwise rotational force on the cone. When the spring exerts a greater counterclockwise rotational force the cone moves the transverse rod downward and the transverse rod ramp moves the push rod to operate the switch assembly lever. When the switch operates, the state of the contacts reverse (i.e. N.O. contacts are closed and N.C. contacts are open).

## 2.2 HIGH OPERATION

For use as a high level sensor (output on falling level), the pivot body is oriented with the enlarged end of the transverse rod down away from the spring cap. When the liquid level is above the displacer assembly, the counterclockwise rotational force of the spring on the cone is greater than the counterclockwise rotational force of the buoyant displacer. This larger force maintains the transverse rod in the down position while the transverse rod ramp pushing on the push rod keeps the switch assembly lever in the operated position. The switch contacts remain in the reversed position.

As the liquid level falls, the displacer assembly loses its buoyancy and the clockwise rotational force on the cone becomes greater than the counterclockwise rotational force of the spring. The transverse rod is shifted upward allowing the push rod to move away from the switch assembly lever. When the switch operates the contacts return to their normal state.

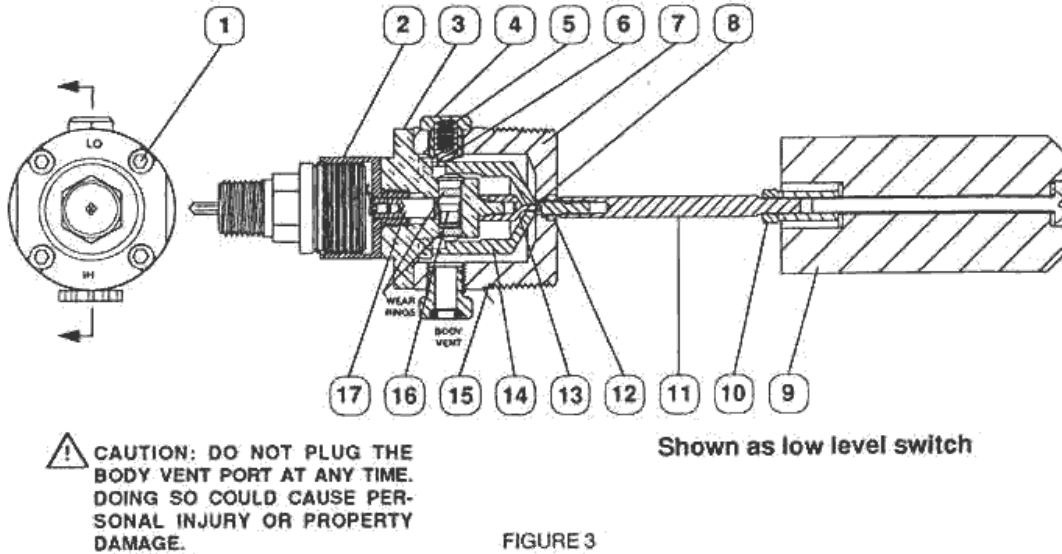

### 3.0

### INSTALLATION

#### 3.1 EXTERNAL CAGE TO VESSEL

It is suggested that the Model L80 be installed in an external cage for maintenance and testing purposes. A recommended piping system for mounting an external cage to a vessel is shown in Figure 2. The valves above and below the cage are required for testing and maintenance purposes.

If a cage with weld connections is used, the level switch should be removed from the cage before welding. This will prevent weld sparks from damaging the displacer assembly. Remove the switch from the cage as per instructions in paragraphs 5.2.1 through 5.2.2 of the FULL DISASSEMBLY section of this manual. After welding install the level switch as per instructions in Section 3.2 INSTALLING SWITCH IN CAGE.

If the cage has threaded or flanged process connections, the level switch does not have to be removed before mounting the switch to the vessel. Cages with 1" NPT process connections may be installed on the vessel with 1", ¾", or ½" O.D. piping. CAUTION: The pressure rating of all pipe, valve, and pipe fittings must meet or exceed the working pressure of the vessel they are to be installed on. Adequate support for long pipe runs should be provided to prevent excessive vibrations of the level switch.

It is recommended that external cages be installed with the process connections as close to vertical and the cage length as close to horizontal as possible. This will insure the proper fluid flow through the cage.

#### 3.2 LEVEL SWITCH INSTALLATION

Before installing a level switch into an external cage or mating flange verify that the level switch is configured for the operation mode required (i.e. direct (low) or reverse (high) action). See Section 4.0 CHANGING MODE OF OPERATION and Figure 5. NOTE: When directly mounting a level switch to a tank or vessel verify that the back of the displacer assembly will be at least ½" (13mm) longer than the 2" connection it is being installed into (See Figure 4).

TOOL REQUIRED: 2.125" open end or suitable adjustable wrench or pipe wrench

- 3.2.1 Clean any dirt or debris from the 2" NPT pipe threads of the switch and mating
- 3.2.2 Apply Teflon tape or other thread sealing compound to the 2" NPT threads on the
- 3.2.3 Apply anti-galling compound to the 2" NPT female thread that the switch is to
- 3.2.4 Screw the switch into the mounting thread and tighten with the wrench. When tight,

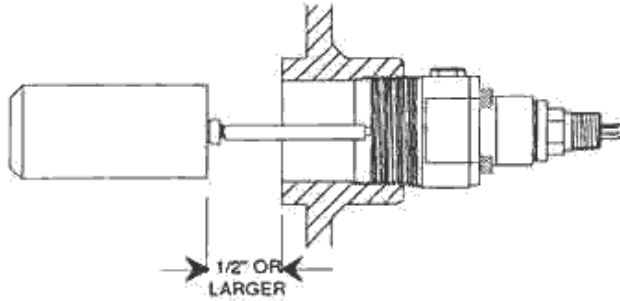

FIGURE 4  
TYPICAL DIRECT MOUNTING

CAUTION: If using a pipe wrench do not allow the wrench jaws to contact the spring cap. Wrench forces may damage the cap and prevent the switch from operating properly.

NOTE: THE SPRING CAP MUST ALWAYS BE IN THE VERTICAL POSITION AS SHOWN IN FIGURE 5 FOR THE SWITCH TO OPERATE PROPERLY.

#### 4.0 ELECTRICAL CONNECTIONS

CAUTION: REMOVE AND LOCK OUT ALL ELECTRICAL POWER BEFORE WORKING ON ELECTRICAL SWITCH LEADS.

BLUE	N.O.	CLOSES ON FALLING LEVEL
BROWN	C	COMMON CONTACT
RED	N.C.	OPENS ON FALLING LEVEL
<b>DPDT SWITCH</b>		
<i>LOW OPERATION</i>		
COLOR	LEVEL	CONTACT FUNCTION
BLUE	N.O.	CLOSES ON RISING LEVEL
BROWN	C	SW. 1 COMMON CONTACT
RED	N.C.	OPENS ON RISING LEVEL
PURPLE	N.O.2	CLOSES ON RISING LEVEL
YELLOW	C.2	SW. 2 COMMON CONTACT
BLACK	N.C.2	OPENS ON RISING LEVEL
<i>HIGH OPERATION</i>		
COLOR	LEVEL	CONTACT FUNCTION
BLUE	N.O.	CLOSES ON FALLING LEVEL
BROWN	C	SW. 1 COMMON CONTACT
RED	N.C.	OPENS ON FALLING LEVEL
PURPLE	N.O.2	CLOSES ON FALLING LEVEL
YELLOW	C.2	SW. 2 COMMON CONTACT
BLACK	N.C.2	OPENS ON FALLING LEVEL

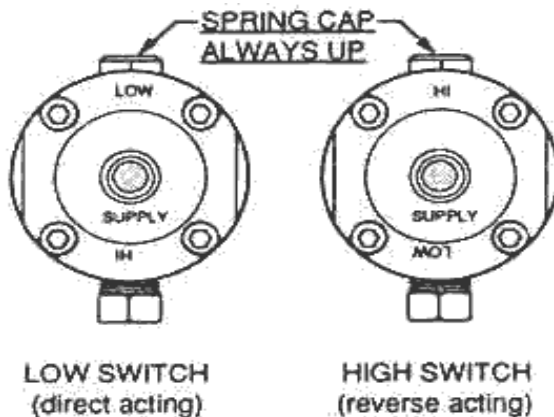

**FIGURE 5**

## 5.0 CHANGING MODE OF OPERATION (Refer to Figure 3)

TOOL REQUIRED: 3/16" Allen wrench

The level switch mode of operation may be easily changed. If the level switch is installed in a pressurized cage or vessel, the pressure does not have to be removed. Figure 5 shows the proper orientation of the level switch function stamping for low and high acting operation.

### 5.1 UPRESSURIZED CAGE OR VESSEL

- 5.1.1 Verify that no pressure is present in the cage or vessel. If this cannot be verified, follow instructions in Section 4.2 PRESSURIZED CAGE OR VESSEL.
- 5.1.2 **CAUTION: REMOVE AND LOCK ALL ELECTRICAL POWER BEFORE WORKING ON ELECTRICAL SWITCH LEADS.** Disconnect all electrical switch lead connections. **DO NOT** attempt to remove the electric switch assembly until the

leads are disconnected. Follow all applicable codes when working with electrical equipment, especially in areas that are classified as hazardous.

- 5.1.3 With the 3/16" Allen wrench remove the four hex socket head cap screws. (1). Rotate the pivot body 180° to change the mod of operation from low to high or form high to low as desired. See Figure 5 for proper pivot body orientation.
- 5.1.4 Replace the four hex socket head cap screws and tighten.
- 5.1.5 Reconnect all electrical switch leads.

## 5.2 PRESSURIZED CAGE OR VESSEL

- 5.2.1 CAUTION: REMOVE AND LOCK ALL ELECTRICAL POWER BEFORE WORKING ON ELECTRICAL SWITCH LEADS. Disconnect all electrical switch lead connections. DO NOT attempt to remove the electric switch assembly until the leads are disconnected. Follow all applicable codes when working with electrical equipment, especially in areas that are classified as hazardous.
- 5.2.2 Use a 3/16" Allen wrench and remove two of the hex socket head cap screws (9) that are diagonally apart. Replace the two hex socket head cap screws just removed with two 1/4" -20 screws or bolts that are 1-1/4" to 1-1/2" long. These serve as a safety stop in the event the level switch has received unknown damage. Rotate the remaining two screws on turn at a time, alternating between the two. The process pressure, acting on the end of the cone (14) that is protruding through the body, will move the pivot body outward as the two screws are turned. When the pivot body has stopped moving, remove the four screws completely. Rotate the pivot body 180° to change the mode of operation (if necessary). See Figure 5 for proper pivot body orientation modes.

CAUTION: THE PIVOT BODY SHOULD MOVE OUTWARD APPROXIMATELY 1/16" AND STOP AS THE DISPLACER ASSEMBLY CONTACTS THE BODY. IF THE PROCESS PRESSURE IS STILL EXERTING A FORCE ON THE PIVOT AFTER IT MOVES 5/64", THEN STOP TURNING THE TWO SCREWS. THE UNIT MAY HAVE DAMAGE THAT WILL ALLOW THE CONE TO DISENGAGE THE O-RING (8) AND THE PROCESS PRESSURE AND MEDIUM WILL ESCAPE THROUGH THE BODY. THE PROCESS PRESSURE WILL HAVE TO BE REMOVED FROM THE CAGE OR VESSEL BEFORE ANY FURTHER DISASSEMBLY IS POSSIBLE.

- 5.2.3 Replace the four hex socket head cap screws and tighten.
- 5.2.4 Reconnect the electrical switch leads.

## 6.0 DISASSEMBLY (Refer to figures 1 & 3)

### TOOLS REQUIRED:

- 7/16", 5/8", & 7/8" open end wrench or adjustable wrench
- 3/16" and 1/8" Allen wrenches
- pliers
- o-ring pick or small screwdriver

CAUTION: ONLY THE SWITCH ASSEMBLY AND PIVOT BODY CAN BE REOMVED FROM THE LEVEL SWITCH UNIT WITHOUT DEPRESSURIZING THE CAGE OR VESSEL. ANY FURTHER DISASSEMBLY WITH PRESSURE PRESENT ON THE CAGE OR VESSEL WILL RESULT I SEVER PERSONAL INJURY OR DAMAGE TO EQUIPMENT.

## 6.1 SWITCH REMOVAL

### 6.3 FULL DISASSEMBLY

CAUTION: ALL PRESSURE MUST BE REMOVED FROM THE CAGE OR VESSEL BEFORE REMOVING ASSEMBLY. DO NOT ATTEMPT TO REMOVE THE ELECTRIC SWITCH ASSEMBLY UNTIL ALL ELECTRICAL POWER IS REMOVED. WORKING ON PRESSURE MAY RESULT IN PERSONAL INJURY OR DAMAGE TO EQUIPMENT.

- 6.1.1 Disconnect all electrical switch lead connections. DO NOT attempt to remove the electric switch assembly until the leads are disconnected. Follow all applicable codes when working with electrical equipment, especially in areas that are
- 6.1.2 Using a 7/8" open end wrench or an adjustable wrench on the hex portion of the electric switch assembly to provide a proper back up, remove all conduit or enclosures attached to the electric switch assembly. DO NOT use channel lock
- 6.1.3 Taking care not to let the push rod (17) fall out of the electric switch assembly, remove the electric switch assembly from the pivot body (3) using the 7/8" wrench.
- 6.1.4 Pull the push rod out of the electric switch assembly. The electric switch assembly cannot be disassembled any further.

### 6.2 PIVOT BODY DISASSEMBLY

CAUTION: THE PIVOT BODY SHOULD MOVE OUTWARD APPROXIMATELY 1/16" AND STOP AS THE DISPLACER ASSEMBLY CONTACTS THE BODY. IF THE PROCESS PRESSURE IS STILL EXERTING A FORCE ON THE VALVE BODY AFTER IT MOVES 5/64", THEN STOP TURNING THE TWO SCREWS. THE UNIT MAY HAVE DAMAGE THAT WILL ALLOW THE CONE TO DISENGAGE THE O-RING (8) AND THE PROCESS PRESSURE AND MEDIUM WILL ESCAPE THROUGH THE BODY. THE PROCESS PRESSURE WILL HAVE TO BE REMOVED FROM THE CAGE OR VESSEL BEFORE ANY FURTHER DISASSEMBLY IS POSSIBLE.

- 6.3.1 For full disassembly, it is necessary to completely remove the pressure from the cage or vessel the switch is installed in. All liquids should be drained to a position below the level switch.
- 6.3.2 Loosen and remove the level switch from the tank, vessel or cage that it is mounted to.
- 6.3.3 Hold the rod (11) with the pliers and rotate it counter-clockwise to remove it from the level switch.
- 6.3.4 Normally it is not necessary to remove the displacer assembly from the rod. If required, loosen the lock nut (10) and unthread the displacer assembly from the rod.
- 6.3.5 Follow instructions in Section 6.1 and 6.2 to remove and disassemble the switch and pivot body.
- 6.3.6 Use the 5/8" wrench and rotate the spring cap (4) counter clockwise to remove it from the body (7). Care should be taken no to lose the spring (5) and spring guide (6).
- 6.3.7 Push the threaded end of the cone (14) through the body.
- 6.3.8 Using an o-ring pick or small screwdriver remove the O-ring (8) form the body.

## 7.0 REPAIR AN ASSEMBLY REFER TO THE SWITCH DATA SHEET FOR REPLACEMENT PART NUMBERS

### TOOLS REQUIRED:

- 7/16", 5/8", & 7/8" open end wrench or adjustable wrench
- 3/16" and 1/8" Allen wrenches
- needle nose pliers
- pliers
- safety solvent
- silicone based o-ring lubricant

- 7.1 Using an appropriate safety solvent, clean all parts.
- 7.2 Inspect the I.D. of the transverse rod bore in the pivot body (13) and the O.D. of the transverse rod (16) for corrosion and excessive wear. The surface of the bore and the ramp on the transverse rod should have a mirror like appearance. Replace any worn or damaged parts.
- 7.3 Examine the push rod (17) for corrosion and excessive wear. Ensure that the tip is still pointed. Replace any worn or damaged parts.
- 7.4 If the level switch has a stainless steel displacer assembly, it should be free of dents, cracks or holes.
- 7.5 Re-install the wear rings if removed.
- 7.6 Install the push rod into the switch assembly and the transverse rod into the pivot body. Both should move freely. NOTE: Care should be taken not to lose these pieces while handling.
- 7.7 Thread and tighten the switch assembly (2) into the pivot body.
- 7.8 Install the body O-ring (8) into the body (7).
- 7.9 Thread the replacement pivot (13) onto the pivot body and tighten.
- 7.10 Lubricate the shaft and the treads on the treaded end of the cone. Install the cone into the body by turning the cone clockwise and pushing gently.
- 7.11 Align the tabs on the pivot body with the slots in the cone and slide the pivot body into the level switch body.
- 7.12 Align the valve body in the correct position for the desired low or high operation, see Figure 5. Install and tighten the four hex socket and head cap screws (1).
- 7.13 Thread the float rod onto the cone and tighten securely with pliers. If the displacer assembly was removed, reinstall and tighten the lock nut securely.
- 7.14 Insert the spring (5) and spring guide (6) into the spring cap. Install the spring cap

into the body and tighten.

- 7.15 Replace the level switch assembly into the tank vessel or cage as per instructions in Section 3.0 INSTALLATION.

## 8.0 SWITCH CALIBRATION

- 8.1 Due to manufacturing tolerances or part wear, it may be necessary to adjust the length of the push rod (10) after installing an electric switch assembly (2).
- 8.2 Install the switch assembly per procedures in paragraph 7.6 and 7.7 of this manual.
- 8.3 Connect a suitable device to test switch continuity to the appropriate switch leads.
- 8.4 If the switch is not installed in a vessel it may be tested by raising and lowering the displacer assembly manually. For a switch installed in a vessel or external cage it is recommended to use the actual process fluid to check for proper switch operation.
- 8.5 Switches that are installed but not practical to operate with the process fluids may be tested by removing the spring cap (4) and the spring (5) then depressing and releasing the spring guide (6).
- 8.6 Should the switch operation have one of the malfunctions as given in the table of 8.7, use procedures given in paragraphs 8.8 thru 8.9 to calibrate the switch.

Switch Response	Calibration
N.O. contacts stay closed	Shorten Push Rod
N.O. contacts stay open	
N.O. contacts stay open	Lengthen Push Rod
N.O. contacts stay closed	

- 8.8 Remove the switch assembly and push rod per procedures in paragraphs 6.1.3 and 6.1.4.
- 8.9 Use pliers to hold the body of the push rod and a 5/64" Allen wrench to turn the set screw on the top of the push rod. Rotate the set screw approximately 30° counterclockwise to lengthen and clockwise to shorten the push rod.
- 8.10 Re-install the switch assembly and retest the level switch. Repeat these procedures as required until the switch functions properly.

## 9.0 RECOMMENDED MAINTENANCE

PROCEDURE	INTERVAL
Test installed switch with process liquid to check for proper operation.	every 30 days
Replace body seal (8)	as required

## TROUBLE SHOOTING:

PROBLEM	POSIIBLE CAUSES	RECOMMENDED ACTION
Level Switch does not function	Loose connection	Verify that the switch leads are properly terminated and all connections are tight.
	Damaged wiring	Check switch leads for cuts.
	Switch assembly (2) damaged	Follow procedures in section 6.0 and replace switch assembly.
	Debris accumulation on push rod (17), transverse	Follow procedures in sections 6.0 and 7.0 to

	rod (16) or under cone (14)	disassemble and clean.
	Trash accumulation on displacer assembly (9).	Remove switch from vessel or cage per procedures in Section 6.3 and clean displacer.
	Level switch not installed properly. Spring cap not in the 'UP' position	Use instructions given in Section 3.0 to properly install the switch.
	Stainless steel displacer assembly (if used) damaged	Remove switch from vessel or cage per procedures in Section 6.3 and replace displacer assembly.
	Specific gravity of fluid too light for switch to function	Consult factory for optional Models available.
Liquid or gas leakage from body vent	Body seal (8) damaged or worn	Replace body seal (8) per instructions in Sections 6.0 & 7.0.