

## INTRODUCTION

The K-Dyne, Inc. pneumatic version of the Model L80 is a 2" NPT mounted liquid level switch. It is typically mounted in a K-Dyne Model C80 cage shown in the Figure 1 for external bridle mounting or may be internally mounted in a 2" NPT (F) connection. Both mounting configurations are shown in Figure 2.

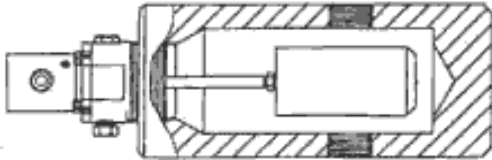

FIGURE 1  
MODEL L80 SHOWN IN MODEL C80 FLANGE

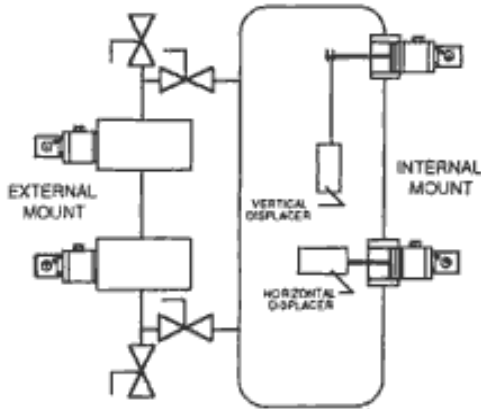

FIGURE 2  
TYPICAL MOUNTING OF MODEL L80  
LEVEL SWITCHES

These sensors send or remove a pneumatic signal when a liquid in a tank or a pressurized vessel reaches a predetermined level. The L80 operation mode as either a low (direct) or high (reverse) acting level switch is selected by rotating the pivot body 180°. The switch functions as a three way 'BLOCK and BLEED' valve. When used as a low acting switch the valve will bleed off a pneumatic signal when the liquid level is below the sensor trip point. For a high acting switch, the valve bleeds off a signal when the liquid level is above the sensor 'trip' point.

## 2.0 PRINCIPLE OF OPERATION (Refer to Figure 3)

The pneumatic version of the K-Dyne, Inc. Model L80 liquid level switch is a multi-functional pneumatic liquid level sensor. Depending on the mode of operation, it functions as a three way, normal closed (N.C.) or normally open (N.O.) pneumatic valve that will operate when the liquid level rises or falls below a fixed point in a tank or pressurize vessel. Valve supply pressures may be form 10 p.s.i. to 35 p.s.i. and 30 p.s.i. is recommended for the most efficient operation.

The switch senses a change in the buoyancy of a displacer assembly (9) inside either a pressurized or an unpressurized vessel. A pivoting action is used to transmit the buoyancy change of the displacer assembly. The bore of the cone (14) contacts a pivot (13) on the pivot body (3). The o-ring (8) provides a pressure tight seal between the body (7) and the shaft of the cone protruding through the o-ring.

Pressure in the vessel acting on the shaft of the cone forces the cone against the pivot. The position of the pivot point, at the center of the o-ring, allows the displacer assembly to move vertically with the liquid level. This motion is guided to act along the axis of the transverse rod (15) by two vertical tabs on the pivot body that mate with notches in the cone. Any vertical motion of the displacer is transmitted by the cone to the ends of the transverse rod. A ramp on the outside diameter of the transverse rod contacts the tip of the valve stem (2G) to operate the valve.

## 2.1 LOW OPERATION

For use as a low-level sensor (output on rising level), the pivot body (3) is orientated with the enlarged end of the transverse rod (15) in the up position, towards the spring cap (4). The displacer assembly weight exerts a clockwise rotational force on the cone through the pivot. The spring (5), acting through the spring guide (6) exerts a counterclockwise rotational force on the cone. When the liquid level is below the displacer assembly, the clockwise force is greater. This greater force causes the cone to push upward against the transverse rod and the seat area of the valve stem (2G) remains positioned away from the ball (2C). In this position the ball is in contact with the seat (2L) and pressure at the 'SUPPLY' port is prevented from entering the 'OUTPUT' port. The 'OUTPUT' port and 'VENT' port are in communication allowing pressure at the 'OUTPUT' port to be vented.

As the liquid level rises and begins to cover the displacer assembly, its buoyancy, in the liquid, reduces the clockwise rotational force on the cone. When the spring exerts a greater counterclockwise rotational force the cone moves the transverse rod downward and the transverse rod ramp pushes the valve stem toward the ball. As the valve stem contacts the ball, the 'VENT' port is blocked and the ball disengages the seat. Pressure from the 'SUPPLY' port then passes through the valve body to the 'OUTPUT' port.

## 2.2 HIGH OPERATION

For use as a high level sensor (output on falling level), the pivot body is oriented with the enlarged end of the transverse rod (15) away from the spring cap (4). When the liquid level is above the displacer assembly, the counterclockwise rotational force of the spring on the cone is greater than the counterclockwise rotational force of the buoyant displacer. This larger force maintains the transverse rod in the down position causing the transverse rod ramp to keep the ball (2C) against the valve stem (2G) and away from the seat (2L). Communication between the 'VENT' port and 'OUTPUT' port is blocked and pressure from the 'SUPPLY' port is allowed to pass to the 'OUTPUT' port.

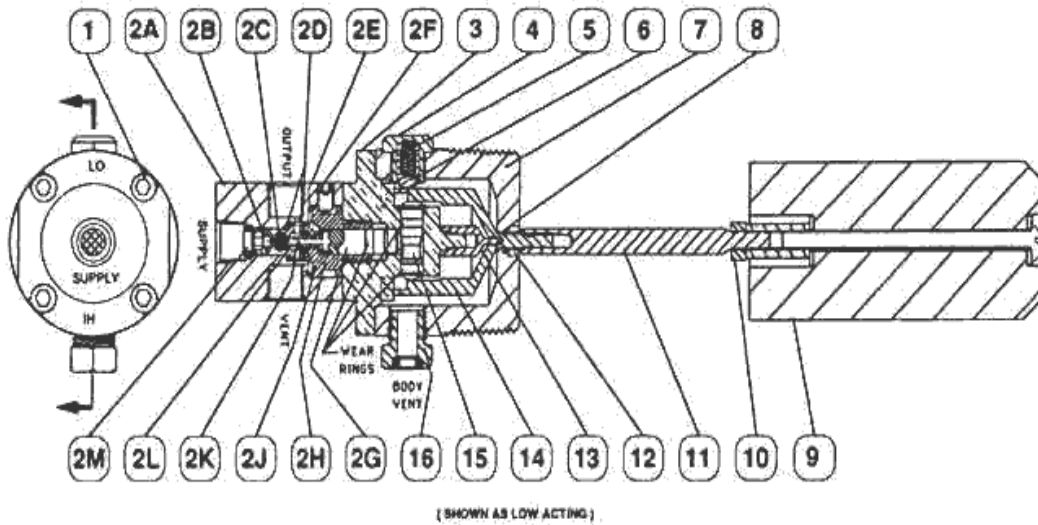

**Figure 3**

As the liquid level falls, the displacer loses its buoyancy and the clockwise rotational force on the cone becomes greater than the counterclockwise rotational force of the spring. The transverse rod is shifted upward allowing the valve stem to follow the transverse rod ramp, positioning the ball against the seat and blocking pressure communication between the 'SUPPLY' and 'OUTPUT' ports. As the ball contacts this seat the tip of the valve stem loses contact with the ball and allows pressure at the 'OUTPUT' port to pass through the valve 'VENT' port.

### 3.0 INSTALLATION

#### 3.1 EXTERNAL CAGE TO VESSEL

It is suggested that the Model L80 be installed in an external cage for maintenance and testing purposes. A recommended piping system for mounting an external cage to a vessel is shown in figure 2. The valves above and below the cage are required for testing and maintenance purposes.

If a cage with butt weld connections is used, the level switch should not be installed in the cage before welding. This will prevent weld sparks from damaging the displacer assembly. After welding install the level switch as per instructions in Section 3.2, LEVEL SWITCH INSTALLATION.

If the cage has threaded or flanged process connections, the level switch does not have to be removed before mounting the switch to the vessel. Cages with 1" NPT process connections may be installed on the vessel with 1", ¾", or ½" O.D. piping. CAUTION: The pressure rating of all pipe, valve, and pipe fittings must meet or exceed the working pressure of the vessel they are to be installed on. Adequate support for long pipe runs should be provided to prevent excessive vibrations of the level switch.

It is recommended that external cages be installed with the process connections as close to vertical and the cage length as close to horizontal as possible. This will insure the proper fluid flow through the cage.

### 3.2 LEVEL SWITCH INSTALLATION

Before installing a level switch into an external cage, tank or vessel verify that the level switch is configured for the operation mode required (i.e. direct (low) or reverse (high) action). See Section 4.0 CHANGING MODE OF OPERATION and figure 5. NOTE: When direct mounting a level switch to a tank or vessel verify that the back of the displacer assembly will be at least 1/2" (13mm) longer than the 2" connection it is being installed into. (See figure 4)

TOOL REQUIRED: 2.125" open end or suitable adjustable wrench or pipe wrench

- 3.2.1 Clean any dirt or debris from the 2" NPT pipe threads of the switch and mating connection
- 3.2.2 Apply Teflon tape or other thread sealing compound to the 2" NPT threads on the switch
- 3.2.3 Apply anti-galling compound to the 2" NPT female thread that the switch is to be installed into.
- 3.2.4 Screw the switch into the mounting thread and tighten with the wrench. When tight, the spring cap must be up as shown in figure 5.

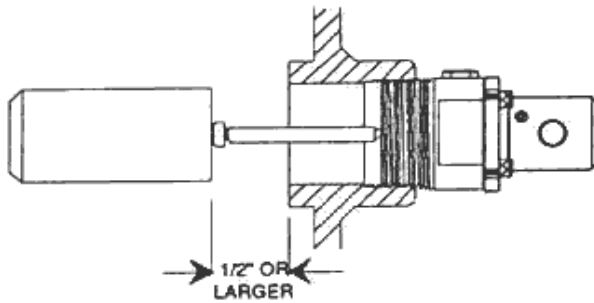

FIGURE 4  
TYPICAL DIRECT MOUNTING

CAUTION: If using a pipe wrench do not allow the wrench jaws to contact the spring cap. Wrench forces may damage the cap and prevent the switch from operating properly.

NOTE: THE SPRING CAP MUST ALWAYS BE IN THE VERTICAL POSITION AS SHOWN IN FIGURE 5 FOR THE SWITCH TO OPERATE PROPERLY.

- 3.2.5 Orientate the 'OUTPUT' port to facilitate connection of instrument lines by loosening the three set screws (2F) on the valve body (2A) and rotating the valve body to the desired position.

CAUTION: DO NOT position the valve body 'VENT' port in the up position. This allows debris and liquids to accumulate in the valve assembly and prevent proper operation. Align the 'VENT' port in either the horizontal or down position.

- 3.2.6 Lightly tighten each of the three set screws first and then firmly tighten them in a clockwise pattern.

### 4.0 CHANGING MODE OF OPERATION (Refer to figure 5)

TOOL REQUIRED: 3/16" Allen wrench

The level switch mode of operation may be easily changed. If the level switch is installed in a pressurized cage or vessel, the pressure does not have to be removed. Figure 5 shows the proper orientation of the level switch function stamping for low and high acting operation.

#### 4.1 UPRESSURIZED CAGE OR VESSEL

4.1.1 Verify that no pressure is present in the cage or vessel. If this cannot be verified, follow instructions in Section 4.2 PRESSURIZED CAGE OR VESSEL.

4.1.2 Block and bleed the instrument pressure from the 'SUPPLY' port. Remove any instrument tubing connected to the 'SUPPLY' and 'OUTPUT' ports.

4.1.3 With the 3/16" Allen wrench remove the four hex socket head cap screws. (1). CAUTION: If the pivot body moves outward as these screws are being removed, the vessel or cage is not completely depressurized. Re-install the screws and perform procedures in Section 4.2 of this manual. Rotate the pivot body 180° to change the mod of operation from low to high or from high to low as desired. See figure 5 for proper pivot body orientation.

4.1.4 Replace the four hex socket head cap screws and tighten.

- 4.2.4 Reconnect the instrument lines.

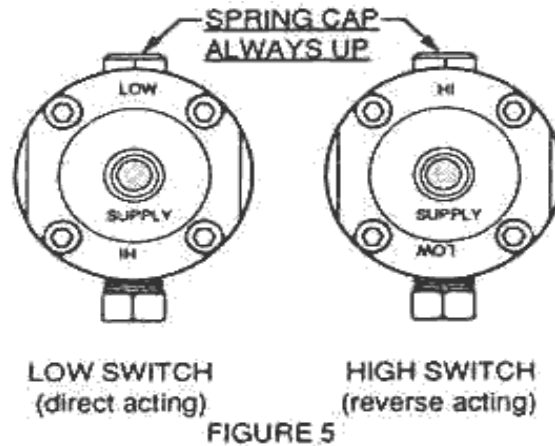

## 5.0 DISSASSEMBLY (Refer to figures 1 & 3)

### TOOLS REQUIRED:

- 7/16" open end wrench or adjustable wrench
- 5/18" open end wrench or adjustable wrench
- 3/16" and 1/8" Allen wrenches
- needle nose pliers
- pliers
- o-ring pick or small screwdriver

**CAUTION: ONLY THE VALVE ASSEMBLY AND PIVOT BODY CAN BE REMOVED FROM THE LEVEL SWITCH UNIT WITHOUT DEPRESSURIZING THE CAGE OR VESSEL. ANY FURTHER DISASSEMBLY WITH PRESSURE PRESENT ON THE CAGE OR VESSEL WILL RESULT IN SEVERE PERSONAL INJURY OR DAMAGE TO EQUIPMENT.**

### 5.1 VALVE DISASSEMBLY

- 5.1.1 Bleed off all instrument pressure from the valve assembly and remove all tubing and fittings from the valve body (2A).
- 5.1.2 Remove the valve assembly from the pivot body (3) by rotation it counterclockwise. NOTE: The valve stem (2G) and stem spring (2H) are free to move and care should be taken not to accidentally let them separate from the valve assembly. To avoid damaging or marring the valve assembly it is recommended to install a pipe fitting into the 'VENT' port of the valve assembly and tap it to remove the valve.
- 5.1.3 Pull the valve stem and stem spring out of the adapter head (2J).
- 5.1.4 To remove the filter disc (2M) from the valve body, insert the tip of an O-ring pick or small screwdriver between the outside diameter of the filter disc and the inside diameter of the 'SUPPLY' port. Pry inward and upward with the pick or screwdriver to rotate the disc edgewise in the port. Use needle nose pliers to pull the disc from the hole.
- 5.1.5 Loosen the three set screws (2F) sufficiently enough to allow the adapter head to be pulled from the valve body (2A). It is not necessary to completely remove these screws.
- 5.1.6 Insert an Allen wrench or other rod shaped tool thru the 'SUPPLY' port and push the ball (2C) and valve seat (2L) out of the valve body.
- 5.1.7 Use a pick or small screwdriver to remove the valve body. This is permanently

installed in the valve body. O-rings (2D) & (2E) from the body and O-rings (2D) & (2K) from the seat. Discard all used seals.

- 5.1.8 DO NOT remove the ball retainer (2B) from the
- 5.1.9 The valve stem wear ring should not be removed unless damaged or an excessive amount of debris has accumulated on the O.D. of the valve stem. These rings are split and may be removed like an O-ring. The wear rings are plastic and breakable, exercise care when removing them.
- 5.1.10 The plastic cap on the valve stem should also not be removed and attempting to do so would change the factory set adjustment. Switch re-calibration would be necessary.

## 5.2 PIVOT BODY DISSASSEMBLY

- 5.2.1 For pivot body removal from a non-pressurized cage or vessel use a 3/16" Allen wrench and remove the four hex socket head cap screws (1).
- 5.2.2 For pivot body removal from a pressurized cage or vessel use a 3/16" Allen wrench and remove the two of the hex socket head cap screws that are diagonally apart. . Replace the two hex socket head cap screws just removed with two 1/4" - 20 screws or bolts that are 1-1/4" to 1-1/2" long. These serve as a safety stop in the event the level switch has received unknown damage. Rotate the remaining two screws on turn at a time, alternating between the two. The process pressure, acting on the end of the cone (14) that is protruding through the body, will move the pivot body outward as the two screws are turned. When the pivot body has stopped moving, remove the four screws completely.

**CAUTION: THE PIVOT BODY SHOULD MOVE OUTWARD APPROXIMATELY 1/16" AND STOP AS THE ROD (11) CONTACTS THE BODY. IF THE PROCESS PRESSURE IS STILL EXERTING A FORCE ON THE PIVOT AFTER IT MOVES 1/8" STOP TURNING THE TWO SCREWS. THE UNIT MAY HAVE DAMAGE THAT WILL ALLOW THE CONE TO DISENGAGE THE O-RING (8) AND THE PROCESS PRESSURE AND MEDIUM WILL ESCAPE THROUGH THE BODY. THE PROCESS PRESSURE WILL HAVE TO BE REMOVED FROM THE CAGE OR VESSEL BEFORE ANY FURTHER DISSASSEMBLY IS POSSIBLE.**

- 5.2.3 Pull the pivot body (3) from the body (7). NOTE: The transverse rod (15) fits loosely in the pivot body and care should be taken not to accidentally let it fall out of the pivot body.
- 5.2.4 Remove the transverse rod from the pivot body
- 5.2.5 Use pliers to hold the O.D. of the pivot point (13) and rotate it counter clockwise to remove it from the pivot body.

## 5.3 FULL DISSASSEMBLY

- 5.3.1 For full disassembly, it is necessary to completely remove the pressure from the cage or vessel the switch is installed in. All liquids should be drained to a position below the level switch.

**CAUTION: ALL PRESSURE MUST BE REMOVED FROM THE CAGE OR VESSEL BEFORE FULL DISSASSEMBLY CAN BE PERFORMED. FAILURE TO REMOVE THE PRESSURE MAY RESULT IN PERSONAL INJURY OR DAMAGE TO EQUIPMENT.**

- 5.3.2 Loosen and remove the level switch from the tank, vessel or cage that it is mounted to.
- 5.3.3 Hold the rod (11) with the pliers and rotate it counter-clockwise to remove it from

- the level switch.
- 5.3.4 Normally it is not necessary to remove the displacer assembly from the rod. If required, loosen the lock nut (10) and unthread the displacer assembly from the rod.
  - 5.3.5 Follow instructions in Section 5.1 VALVE DISASSEMBLY to remove and disassemble the valve body.
  - 5.3.6 Use the 5/8" wrench and rotate the spring cap (6) counter clockwise to remove it from the body (5). Care should be taken no to lose the spring (7) and spring guide (8).
  - 5.3.7 Push the threaded end of the cone (14) through the body.
  - 5.3.8 Using an o-ring pick or small screwdriver remove the O-ring (8) form the body.

## 6.0 REPAIR AN ASSEMBLY REFER TO THE SWITCH DATA SHEET FOR REPLACEMENT PART NUMBERS

### TOOLS REQUIRED:

- 7/16" open end wrench or adjustable wrench
  - 5/18" open end wrench or adjustable wrench
  - 3/16" and 1/8" Allen wrenches
  - needle nose pliers
  - pliers
  - safety solvent
  - silicone based o-ring lubricant
- 6.1 Using an appropriate safety solvent, clean all parts.
  - 6.2 Inspect the I.D. of the transverse rod bore in the pivot body (3) and the O.D. of the transverse rod (15) for corrosion and excessive wear. The surface of the bore and the ramp on the transverse rod should have a mirror like appearance. Replace any worn or damaged parts.
  - 6.3 Examine the valve stem (2G) for corrosion and excessive wear. The small sealing diameter should have a mirror like surface and the seat at the tip should be free of indentations. Insure that the cap that contacts the transverse rod ramp is still pointed. Replace any worn or damaged parts.
  - 6.4 The seat (2L) at the contact point of the ball (2C) should be free of any indentations. The ball should also have a polished finish and have no corrosion or gouges.
  - 6.5 If the level switch has a stainless steel displacer assembly, it should be free of dents, cracks or holes.
  - 6.6 Lubricate all seals from the repair kit with a silicone based lubricant.
  - 6.7 Lightly lubricate the filter disc (2M) O-ring and push the disc edgewise into the center of the 'SUPPLY' port until it stops. Start rotation the disc across the port so the filter screen will be toward the ball retainer (2B) while pushing downward on the outside edge that is closest to the end of the valve body.
  - 6.8 Use a blunt rod, such as an Allen wrench, and push the edge of the disc as far down a possible. Using the end of an O-ring pick or small screwdriver inserted between the disc O.D. and 'SUPPLY' port I.D., press firmly on the O-ring around the circumference of the filter disc to completely seat it in the port.
  - 6.9 Install the O-rings (2D) and (2E) into the valve body and the O-rings (2D) and (2K) on the seat. O-ring (2K) is a blue color.
  - 6.10 Place the ball into the valve body and install the seat. Place the adapter head (2J) into the valve body and tighten he set screws (2F).
  - 6.11 Lubricate the valve stem and transverse rod. DO NOT excessively lubricate, this will prevent proper operation of the level switch. Be sure to re-install the wear rings

- if removed.
- 6.12 Install the valve stem and stem spring (2H) into the adapter head (2J). Depress the valve stem down into the body and release. It should move completely and freely outward. NOTE: Care should be taken not to lose these pieces while handling.
  - 6.13 Insert the small diameter of the transverse rod (15) into the counter bored side of the hole of the pivot body (3), and push it full into the pivot body. Slide it in and out approximately 1/8" to verify that it is not binding.
  - 6.14 Thread the valve into the pivot body. To tighten the valve assembly and to avoid damaging or marring the valve assembly it is recommended to install a pipe fitting into the 'VENT' port of the valve assembly and tap it lightly.
  - 6.15 Install the body O-ring (8) into the body (7).
  - 6.16 Thread the replacement pivot (13) onto the pivot body and tighten. Lubricate the pivot point and the square tabs on the pivot body.
  - 6.17 Lubricate the shaft and the treads on the treaded end of the cone. Install the cone into the body by turning the cone clockwise and pushing gently.
  - 6.18 Align the tabs on the pivot body with the slots in the cone (14) and slide the pivot body into the level switch body.
  - 6.19 Align the valve body in the correct position for the desired direct or reverse operation, see figure 5. Install and tighten the four hex socket and head cap screws (1).
  - 6.20 Thread the rod (11) onto the cone and tighten securely with pliers. If the displacer assembly was removed, reinstall and tighten the lock nut (10) securely.
  - 6.21 Insert the spring (5) and spring guide (6) into the spring cap (4). Install the spring cap into the body and tighten.
  - 6.22 Replace the level switch assembly into the cage or mating flange as per instructions in Section 3.0 INSTALLATION.

## 7.0 SWITCH CALIBRATION

- 7.1 Due to manufacturing tolerances or part wear, it may be necessary to adjust the valve stem (2G) length when a new or repaired valve assembly (2) is installed.
- 7.2 Install the repaired or new valve assembly per procedures in paragraph 6.14 of this manual.
- 7.3 Connect a suitable instrument supply to the valve assembly 'SUPPLY' port and an indication device such as a pressure gauge to the 'OUTLET' port.
- 7.4 If the switch is not installed in a vessel it may be tested by raising and lowering the displacer assembly manually. For a switch installed in a vessel or external cage it is recommended to use the actual process fluid to check for proper switch operation.
- 7.5 Switches that are installed but not practical to operate with the process fluids may be tested by removing the spring cap (4) and the spring (5) then depressing and releasing the spring guide (6).
- 7.6 Should the switch operation have one of the malfunctions as given in the table of 7.7, use procedures given in paragraphs 7.8 thru 7.11 to calibrate the switch.

Switch Response	Calibration
Output signal does not bleed off	Shorten Valve Stern
Slow bleed off of output signal	
No output signal	Lengthen Valve Stern
Slow increases of output signal	

- 7.8 Remove the valve assembly, valve stem and stem spring per procedures in paragraphs 5.1.2 and 5.1.3.
- 7.9 Insert a small dowel, pick or Allen Wrench into the hole on the plastic cap of the valve stem and one in the cross drilled hole of the stem. With the plastic cap facing up, rotate the cap approximately 30° counterclockwise to lengthen and clockwise to shorten the stem.

- 7.10 Re-install the valve assembly onto the switch and then retest the switch.  
 7.11 Repeat these procedures as required until the switch is functioning properly.

8.0 RECOMMENDED MAINTENANCE

PROCEDURE	INTERVAL
Test switch in place with liquid to check for proper operation.	every 30 days
Clean vent ports of debris	every 30 days
Replace body seal (8)	as required

TROUBLE SHOOTING:

PROBLEM	POSSIBLE CAUSES	RECOMMENDED ACTION
Level Switch does not function	Debris blocking the valve vent port	Clean vent port and test switch.
	Debris on the inside of the cone	Remove pivot body (3) per procedures in Section 4.0 and clean cone I.D.
	Valve not functioning	Follow procedures in section 5.2 and 6.0 to disassemble and clean valve. Replace seals if necessary.
	Supply port plugged	Disconnect all instrument tubing and clean supply port. Clean instrumentation system filters.
	Connecting tubing plugged	Remove and clean or replace instrument tubing. Clean instrumentation system filters.
	Debris accumulation on displacer assembly (9) or in external cage.	Remove switch from vessel or cage per procedures in Section 6.0 and clean.
	Level switch not installed properly. Spring cap not in the 'UP' position	Use instructions given in Section 3.0 & 4.0 to properly install the switch.
	Specific gravity of fluid too light for switch to function	Consult factory for optional Models available
	Stainless steel displacer assembly (if used) damaged	Remove switch from vessel or cage per procedures in 5.3 and replace displacer assembly.
Constant gas leakage from vent port in valve	Valve seals (2K) & (2D) damaged or worn	Follow procedures in Sections 5.1 & 6.0 to disassemble and replace the seals.
	Debris on valve seat (2L) or valve stern (2G)	Follow procedures in Sections 5.1 & 6.0 to disassemble and clean valve.
Liquid or gas leakage from body vent	Body o-ring (8) damaged or worn	Replace body seal (8) per instructions in Sections 5.0 &

		6.0.
--	--	------